

Operation & Maintenance Manual

Models: X5L02250, X5L03528, X5L07056, X5L14000 & X5L20000



READ THIS MANUAL BEFORE USING THESE PRODUCTS. This manual contains important safety, installation and operation information

NOTICE: OSHA and ASME B30 require Inspection before placing into service and before each use. (See section 4.0 INSPECTION AND TEST in this manual)

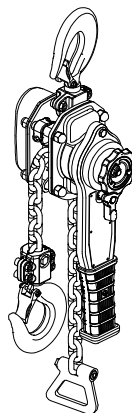

WARNING

To avoid serious injury or death:

1. Only allow people, trained in safety and operation of this product, to operate the hoist.
2. Only operate a hoist if physically fit to do so.
3. After use, or in a non-operational mode the hoist should be secured against unauthorized use
4. When a "DO NOT OPERATE" sign is placed on the hoist, do not operate until the sign has been removed by designated personnel.
5. Periodically, inspect the hoist thoroughly and replace worn or damaged parts. (See 4.0 INSPECTION and TEST)
6. Before use ensure that attachment points and supporting structure are adequate. If in doubt consult a qualified professional.
7. Always visually inspect the hoist for wear or damage by operator before each use
8. Always check that the load is seated in the saddle of the hook and the hook latch is engaged.
9. Always pay attention to the load and surroundings when operating.
10. Always ensure that the operator and all other people are clear of the path of the load.
11. Do Not use a hoist which inspection indicates is worn or damaged.
12. Do not use if hook latch has been sprung, broken or missing.
13. Do not support the load on the tip of the hook.
14. Do Not place your hand inside the throat area of a hook.
15. Do Not use the hoist load chain as a sling.
16. Do not operate hoist if chain jumping, excessive noise, jamming, or binding occurs.
17. Do not force a chain or hook into place by hammering.
18. Do not allow the load chain to run over a sharp edge.
19. Do Not allow anyone to stand on a suspended load.
20. Do Not swing a suspended load.
21. Do Not use the hoist chain as an electric welding ground.
22. Do Not leave a load suspended when hoist is unattended.
23. Do Not operate if restricted in forming a straight line between hooks
24. Do Not operate with lever extension or with other than manual power
25. Do Not operate with a twisted, kinked, or damaged chain
26. Do Not operate a damaged or malfunctioning hoist
27. Do Not lift people or loads over people
28. Do Not lift more than WLL (Working Load Limit)

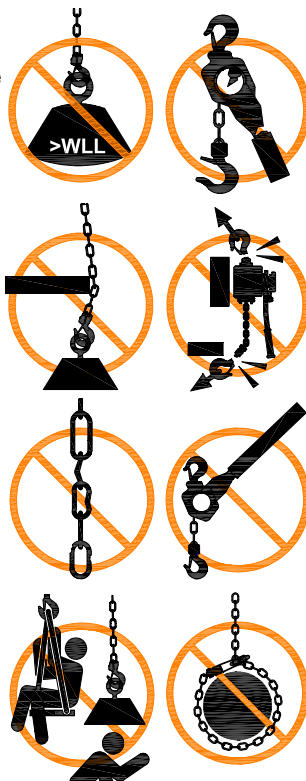

HOIST NAMEPLATE with basic warnings and information as required by ASME B30:

It is recommended to copy; Model, and Serial number into the blocks on top of the cover of this manual. Make a copy of this manual available to all operators. Note that the "Overload Protection" label will only appear on units so equipped. Below, the warnings are translated:

WARNING

To avoid serious injury or death

Read manual before operating

Do Not remove or obscure this label

Do Not operate if restricted in forming straight line between hooks

Do Not operate with lever extension or with other than manual power

Do Not operate with a twisted, kinked, or damaged chain

Do Not lift people or loads over people

Do Not operate a damaged or malfunctioning hoist

Do Not lift more than WLL

1.0 OPERATION:

The operator must read and understand Warnings and operational instructions in this manual and as displayed on the hoist.

Set up using free chain mode to pull chain in or out by hand

1. Under no load, move the selector to neutral "N" position.
2. Pull the hand wheel out then counterclockwise (CCW) to hold position. (Do Not attempt to pull out or rotate when hoist is loaded)
3. Pull chain in or out by hand. (Too quick or fast and the brake will set and the set up must be repeated.)
4. Attach hook to load.

Set the Brake and prepare to load

5. Quick pull on the tail chain to tighten the chain against the load or turn the hand wheel clockwise (CW). The hand wheel will then return to the "in-position" when the chain is snug against the load. (Without load, hold the chain with bottom hook and turn the hand wheel clockwise CW)
6. Turn the selector to the up "U" position.

Load the hoist to begin lift or pull.

7. Ratchet the lever in the clockwise (CW) direction to lift or pull. Move selector to Down "D" and ratchet in the counterclockwise (CCW) direction to lower the load.
8. Confirm proper operation by Lifting or pulling until the full load is suspended. Stop and check if rigging and the hoist holds the load without slipping. If confirmed then continue the lift or pull.

Detaching the Load

9. Secure the load.
10. Release tension on the chain by turning the selector to down "D" and ratchet the lever in the counterclockwise (CCW) direction until enough slack to detach the hook. Pull chain out by hand to provide resistance to allow the lever to ratchet.

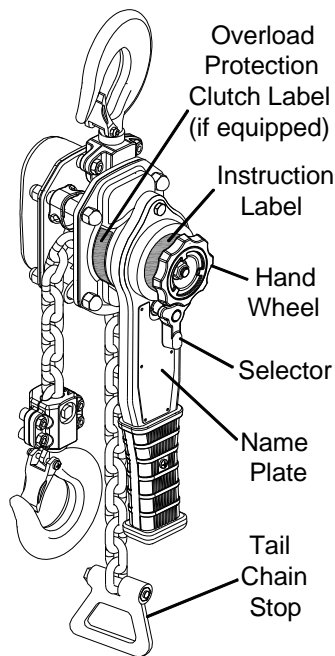
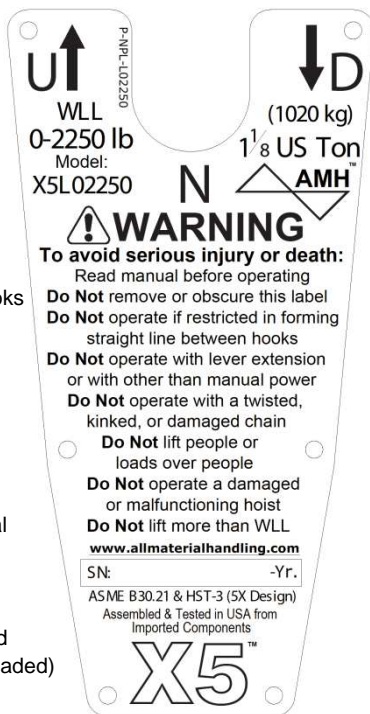



**PULL OUT in Neutral
TO FREE CHAIN**

**HOLD CHAIN AND
TURN TO LOAD**

2.0 SPECIFICATIONS:

These products exceed requirements of ASME B30.21 “Safety Standard for Lever Hoist” and ASME HST-3 “Performance Standard for Manually Operated Lever Hoist. In addition the ultimate strength is 5 times Working Load Limit (WLL) meeting structural requirement of ASME HST-3 Appendix A, for use in marine and other applications as specified by US Department of Defense DOD.

Operating temperature: -40°F (- 40°C) ~ 140°F (60°C)

APEX rating: Ⓢ II 3 GD c IIB 60° C X for limited use in Hazardous Environments.

Materials: Load bearing parts are free of cast iron. Brake is asbestos free. Paints and coatings are lead and chromate free. Load chains are high strength grade 100 zinc plated.

	US tons	1 1/8T	1 3/4T	3 1/2T	7.0T	10.0T
	pounds	2,250	3,528	7,056	14,000	20,000
	(kg)	1020	1600	3200	6350	9070
Model	AMH	X5L02250	X5L03528	X5L07056	X5L14000	X5L20000
Falls	No.	1	1	1	2	3
G100 Chain	(mm)	5.6*17	7.1*20	10*28	10*28	10*28
Pull to WLL	pounds	52	72	84	86	88
	(n)	231	320	374	383	391
125% Proof Load Test	pounds	2813	4410	9625	17500	35000
	(tonnes)	1.28	2.00	4.37	7.94	11.34

3.0 OPTIONS AND ACCESSORIES

Hook Option Part Numbers			
	Self Locking Top or Bottom	Shipyard Hook Top or Bottom	Shipyard Hook Latch Kit
1 1/8T	HOOK-SL010		
1 3/4T	HOOK-SL016	P-LA016-31-47SYHK	P-LA016-47SYHK
3 1/2T	HOOK-SL032	P-LA032-31-47SYHK	P-LA032-47SYHK

Top Hook Extender Kits include adapters to extend the reach of the top hook. They are available as a bolt on solution. The standard top hook, that is removed to install, can be utilized + any length of load chain (7) purchased separately.

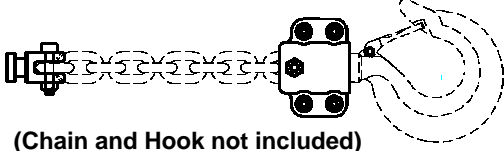
Extender Kit Part Number  WLL	 (Chain and Hook not included)
1 1/8T	HOOK-EXT02250
1 3/4T	HOOK-EXT03528
3 1/2T	HOOK-EXT07056

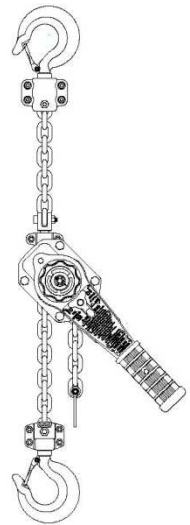

4.0 INSPECTION AND TEST

Note: Check local and governmental requirements and specifications to insure compliance in addition to those listed below. If any conflict, utilize the most stringent requirement.

Inspections required per ASME B30.21 and OSHA

INSPECTION RECORDS (when required)

Inspections are the responsibility of a qualified person designated by the owner. Dated inspection reports shall be maintained for the service life of the product. They are to be filed by the serial number, stamped into the name plate, and made available for inspection at any time.

All inspections shall be by a designated person who is competent and qualified to perform the type inspection being utilized.

If any fault is discovered, during any inspection, then the unit shall be taken out of service and quarantined. A qualified person shall then make determination of repair or disposition.

PREOPERATION INSPECTION of new unit or a unit that has not been in use for more than 1 month is required prior to use and **must be recorded**. The inspection shall consist of:

New Hoists are to be inspected before use and **must be recorded**. No load test is required if tested and certified when manufactured. The new hoist test certification supplied with the hoist should be filed with the initial Preoperation Inspection. The date of this Preoperation Inspection, **not the date on the manufactures load test**, will become the start date for entering a new unit into service and determining timing of future periodic inspections. **Units returned to service after inactivity of more than one month**, does not affect the date of the next periodic test as previously scheduled.

See sample PREOPERATION INSPECTION form in back of this manual

Inspect the following:

- a) Proper operation and any unusual sounds.
- b) Visually inspect hooks for deformation or bending and to verify latches function.
- c) Visually inspect load chain for twist, damage or excessive wear between links.
- d) Visually inspect the hoist body and lever for damage.
- e) Fasteners are in place and tight.
- f) Tail chain stop is in place.
- g) Nameplate with warnings and operation instruction label are in place and legible.

FREQUENT INSPECTION is required before each use but not required to be recorded. It is to be performed by the operator or other designated persons and shall consist of:

Inspect for a), through g) items listed in Preoperation Inspection plus the following:

- h) Visual inspection to determine that the unit is not compromised by corrosion or debris and can operate as intended.

- i) Make a trial lift or pull of a few inches and then stop to determine the hoist operates as intended.
- j) Continual observation during use for any damage or change in operation.

PERIODIC INSPECTION is required annually as a minimum and must be recorded. Periodic Inspection may be required more often as determined by severity of service or as experience dictates. Consult ASME B30.21 for determination of service and instruction. Periodic inspection is also required for repaired units. This inspection requires disassembly and load test prior to being returned to service.

See sample PERIODIC INSPECTION form in back of this manual

Inspect for a), through j) items listed in Preoperation and Frequent Inspection plus the following:

- k) Disassemble lever end of hoist to expose the brake components. Inspect brake pawls, disc, springs and ratchet surfaces for contamination or abnormal wear.
- l) Inspect; chain, springs and load bearing parts per section 5.0 INSPECTON MEASUREMENTS as illustrated in this Manual.
- m) Disassemble hook blocks and check hooks 100% for any sign of cracks, bending, twist or stretching and opening measurement per section 5.0 INSPECTON MEASUREMENTS as illustrated in this Manual.
- n) Check chain wheel or wheels for smooth operation and visually for wear.
- o) Check chain guide and guards for damage.
- p) Load test to Min. of 125% WLL (Max. 150%). During which confirm function is as intended. After the test load is released inspect again for requirements of a) through g).

5.0 INSPECTON MEASUREMENTS:

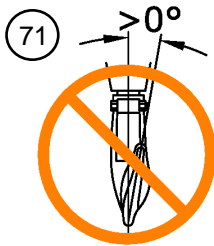

Hooks

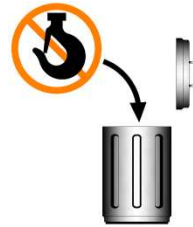
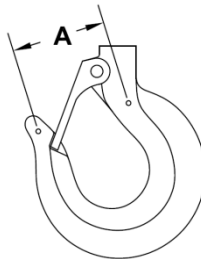

A Max.

1½ US Ton (1t metric)		1.85 in (47mm)
1¾ US Ton (1.6t metric)		2.24 in (57mm)
3½ US Ton (3.2t metric)		2.72 in (69mm)
7 US Ton (6.3t metric)		3.19 in (81mm)
10 US Ton (9t metric)		4.06 in (103mm)

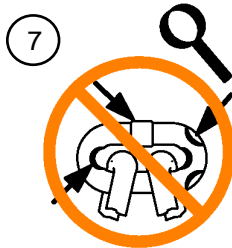

Chain

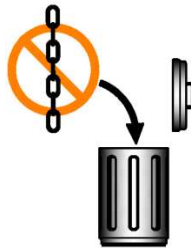
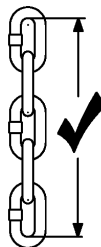

Max.

1½ US Ton	C5.6H17Z G100	3.45 in (87.6mm)
1¾ US Ton	C7.1H20Z G100	4.09 in (104mm)
3½, 7 & 10 US Ton	C10H28Z G100	5.71 in (145mm)

20

Brake Ratchet Disc **D Min.** **T Min.**

1½ & 1¼ US Ton	2.40 in (61mm)	0.28 in (7mm)
¾, 7 & 10 US Ton	2.79 in (71mm)	0.28 in (7mm)

25

Spring, Ratchet **L**

1½ & 1¼ US Ton	< 1.20 in. (30.5 mm), > 1.52 in (38.5mm)
¾, 7 & 10 US Ton	< 1.79 in. (45.5 mm), > 1.91 in (48.5mm)

32

Brake Spring, Inner **L Min.** **D°**

1½ & 1¼ US Ton	1.26 in (32mm)	0° +/- 10°
¾, 7 & 10 US Ton	1.46 in (37mm)	30° +/- 10°

34

Brake Spring, Outer **L Min.** **D°**

1½ & 1¼ US Ton	2.17 in (55mm)	180° +/- 10°
¾, 7 & 10 US Ton	2.56 in (65mm)	180° +/- 10°

6

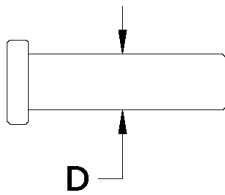

Top Hook Pin

1½ US Ton	0.45 in (11.4mm)
1¾ US Ton	0.45 in (11.4mm)
3½, 7 & 10 US Ton	0.60 in (15.2mm)

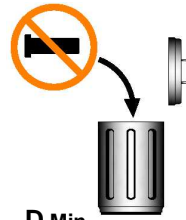

D Min.

8

1

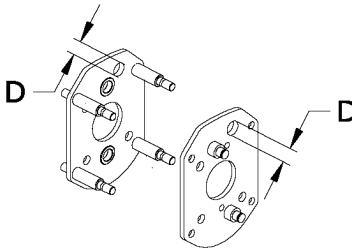

Top Hook Pin Holes

1½ US Ton	0.50 in (12.7mm)
1¾ US Ton	0.50 in (12.7mm)
3½, 7 & 10 US Ton	0.66 in (16.7mm)

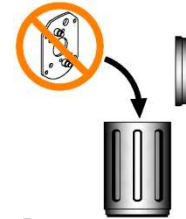

D Max.

75

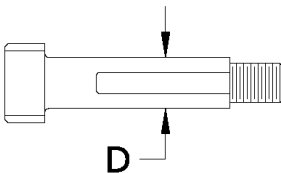

Chain Pin

1½ US Ton	0.28 in (7.1mm)
1¾ US Ton	0.37 in (9.5mm)
3½, 7 & 10 US Ton	0.49 in (12.4mm)

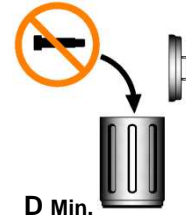

D Min.

70

80

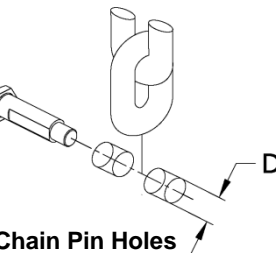

Chain Pin Holes

1½ US Ton	0.33 in (8.5mm)
1¾ US Ton	0.43 in (11.0mm)
3½, 7 & 10 US Ton	0.55 in (14.0mm)

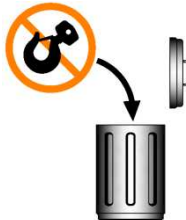

D Max.



WARNING

To avoid serious Injury wear eye protection when near where hoist are being worked on

6.0 TOOLS REQUIRED FOR SERVICE

- External retaining ring pliers (small size)
- Wrenches: 6, 8, 10, 12, 13 and 17 mm
- Socket wrench: 6, 8, 10, 12, 13 and 17 mm
- 6 inch caliper (0.001 in. increments).
- Soft face hammer

7.0 LUBRICANTS REQUIRED FOR SERVICE

- No 2 lithium grease for gearing & bearings (temperature -40°C~120°C)
- Gear oil for the load chain (any viscosity) (Dry lubricant can be substituted.)

8.0 DISASSEMBLY:

Hoist repair and inspection should not be attempted unless by capable and qualified persons familiar with this product. (During disassembly, parts should be cleaned and inspected per section 5.0 INSPECTON MEASUREMENTS as illustrated in this Manual.

To access brake, lay the hoist on the gear side for disassembly from the lever side:

Reference the exploded parts illustration drawings in this manual. Begin by loosening nut (36) while holding down on (35) as it is spring loaded. Slowly remove (35) allowing the spring (34) to release. Remove hand wheel (33) and spring (32). Remove the lever (27) by loosening bolt (29) and nuts (31). Remove cam (28) and the brake driver (22) or overload protected brake driver assembly (22C).

Note: If equipped with an overload protection assembly (22C), it is pre-set at the factory to slip if the hoist is severely overloaded. It is not recommended to disassemble or reset this device by other than an AMH authorized service center. If this assembly malfunctions it is recommended that it be replaced.

Loosen nuts (15) on the lever side and remove lower lever assembly (21) to expose the brake disc (20) pawls, springs and retaining rings (17).

To access the chain wheel (5), chain stripper (4), chain guards (3), bearings (2) and the top hook assembly remove the brake side frame plate (1).

To access the gearing: If continuing the disassembly from above, Loosen nuts (15) on the gear side and remove gear cover (13). Planet gears (9), pinion (12), thrust washer (11) and output gear (10) and top hook attachment pin (6) can all be removed by hand. If accessing the gearing without first disassembling from the lever side; the pinion (12), thrust washer (11) and output gear (10) may not be removed.

To disassemble hooks simply view the parts exploded drawing. The top hook assembly (70) can be easily detached from the hoist body by removing the gear cover (13) and pin (6) within.

9.0 ASSEMBLY:

Hoist repair and inspection should not be attempted unless by capable and qualified persons familiar with this product.

To reassemble the power unit: Reference the exploded parts illustration drawings in this manual. Assemble in the reverse order from section 8.0 DISASSEMBLY above with the additional instruction provided below:

Assembly of gearing: Assemble gearing with a liberal coating of #2 chassis grease on the roller bearings (2), hardened bushings, gear teeth (9) (10) & (12) and thrust washer (11). A light coat of grease should be applied to the entire pinion shaft (12), wipe excess from the spline end before assembly as it passes into the brake area. Install bearing (2) in the gear side frame plate (8) and chain

wheel (5) into the bearing. Install output gear (10) over the chain wheel (5) spline. Insert pinion shaft (12) through thrust washer (11) and then into the chain wheel (5). Insert top hook pin (6). Insert the planet gears (9) to be timed with marks aligned as per the below illustration. **Be sure hook pin (6) is in place then attach gear cover (13) to the gear side frame plate (8).**

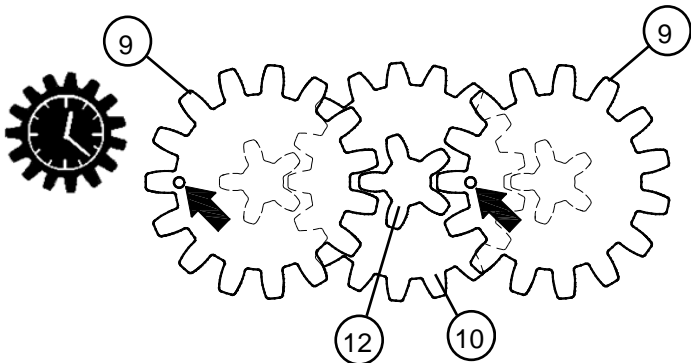

Assemble the Chain wheel and chain: Assemble the chain pull stop (16) to one end of the chain. Before or after assembly, lubricate chain with any viscosity gear oil. Apply so that it reaches contact areas between the links then wipe off excess (dry lubricant may be substituted).

Lay the gear end assembly on a workbench with pinion shaft (12) up. Place the load chain (7) around the chain wheel (5). **Insure the chain weld is facing away from wheel, (see illustration below)** and that the chain stop (16) is on the right hand side and perpendicular to the frame plates without twist in the chain. Looking at the gear side frame (8), with hook pin (6) at the 12 o'clock position, insert the stripper (4) at the 7 o'clock position, and guides (3) at 4 and 10 o'clock positions. Place the top hook assembly (70) over the protruding pin (6). Position brake side frame plate assembly (1) over the parts while aligning; bosses on the stripper and guides, hook pin (6) and spacer bolts to the mating holes.

Hoist Drive Wheel Only

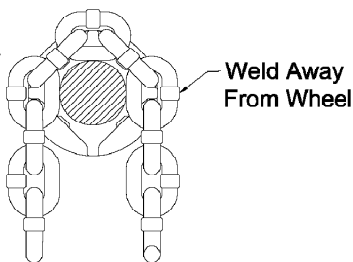

Note: X5 hoists are designed to allow the chain weld to be assembled in any orientation. However, ASME Standard B30.21-4.3.1 (f) implies the chain is to be assembled per this instruction.

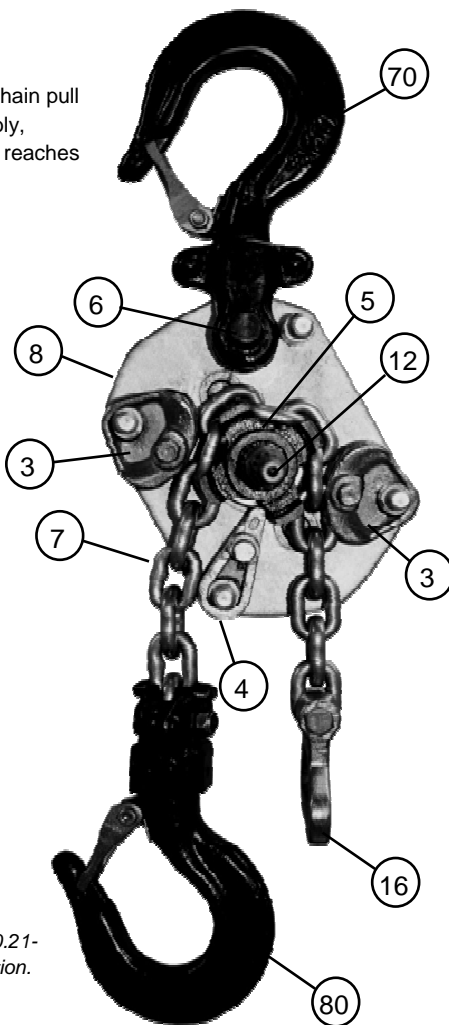

Assembly of the brake components:

After assembly of all parts, between the gear cover (13) and the brake side frame plate (1), place the brake seat (19) down on the pinion shaft (12). Place the brake ratchet disc (20) onto the brake seat (19). Assemble (17) brake pawls, pawl springs and retainers in the position shown in the illustration onto the brake side frame plate (1). If assembled correctly the pawls (17) must snap into the teeth of the brake disc and stop the disc from rotating in the counter clockwise direction.

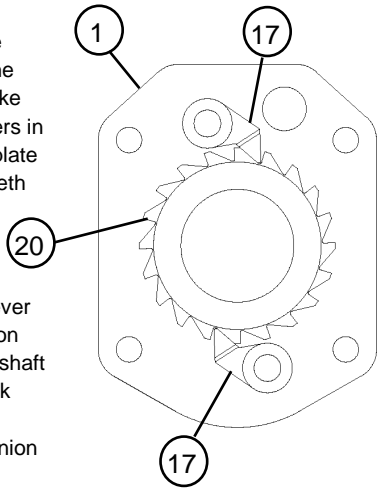

Assembly of control components:

After assembly of the brake components, assemble the lower lever assembly (21). Install the brake driver (22), or overload protection clutch kit (22C) if equipped, clockwise over the threaded pinion shaft (12) until snug against the brake disc (20) while holding the hook side chain. Attach the lever assembly (27) to the lower lever assembly (21). Install the brake cam (28) down and over the pinion spline (12) and index slightly to the right of center per the below diagram.

Place the inner brake spring (32) into brake driver (22) or (22C) if equipped with overload protection. Install the hand wheel (33). While holding the hook side chain, turn hand wheel clockwise until snug with the brake spring (32) then rotate the hand wheel 120° clockwise while pushing in until it drops down. Continue to push in and rotate clockwise until the hand wheel drops again into home position and will not rotate further, (see below illustration). Turn the Up-Down selector to the up position to hold the hand wheel (33) in the home position.

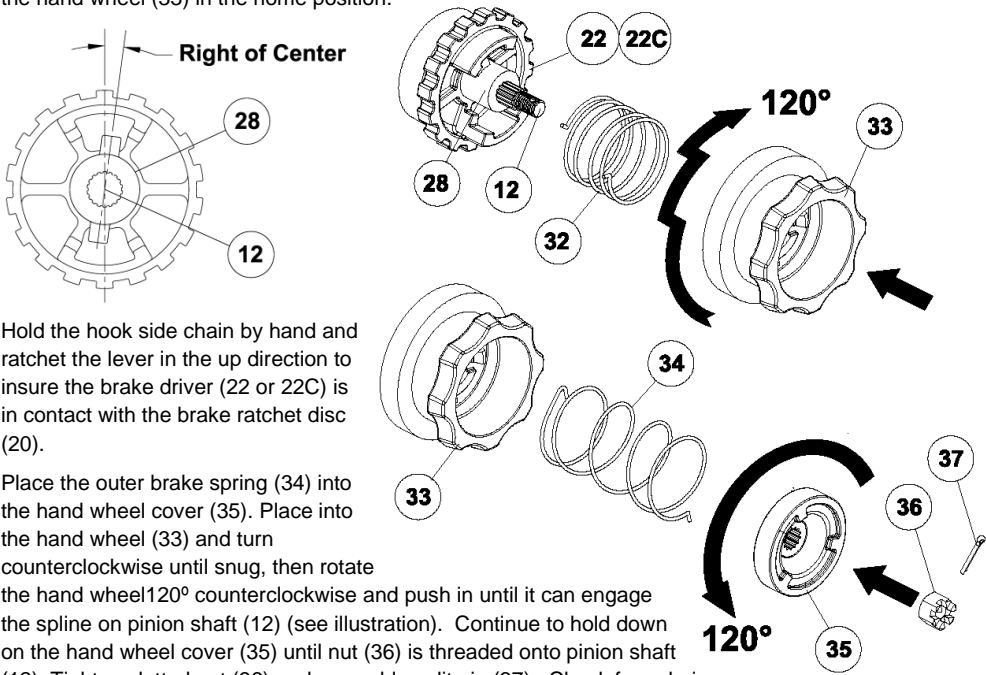

Hold the hook side chain by hand and ratchet the lever in the up direction to insure the brake driver (22 or 22C) is in contact with the brake ratchet disc (20).

Place the outer brake spring (34) into the hand wheel cover (35). Place into the hand wheel (33) and turn counterclockwise until snug, then rotate the hand wheel 120° counterclockwise and push in until it can engage the spline on pinion shaft (12) (see illustration). Continue to hold down on the hand wheel cover (35) until nut (36) is threaded onto pinion shaft (12). Tighten slotted nut (36) and assemble split pin (37). Check free chain function by hand at no load to insure assembly is correct. Before returning the hoist to service it must be load tested and recorded per Periodic Inspection requirements. See section 4.0 INSPECTION AND TEST in this manual.

10.0 TROUBLE SHOOTING

Trouble	Cause	Cure
Hand Wheel (33) does not move in or out	Selector not in neutral "N" position	Move Selector to neutral "N"
	Hoist is loaded	Never attempt to pull hand wheel out when the hoist is loaded.
	Improper assembly	Requires service for repair
Free chain mode does not allow chain to be pulled freely	Chain pulled too fast or accelerated too quickly causing the brake to set	Reset the hand wheel (33) and pull load chain with less force
	Assembly of outer brake spring (34) may be preloaded in excess of 120°	Requires service for repair.
Hoist will not lift or lower at no load	Brake is not set	See section 1.0 OPERATION in this manual: instructions 5 and 6
	Lever moves without clicking, chain does not continue to move in or out	There must be some resistance to cause the lever to ratchet. Hold or pull the slack chain by hand while ratcheting the lever. Or, use the free chain mode to easily position the chain.
	Improper assembly of brake components between the hand wheel (33) and brake driver (22)	Requires service for repair. Re-assemble components between the hand wheel (33) and brake driver (22) per instruction and illustration in section 9.0 ASSEMBLY in this manual.
Hoist will not lift. No clicking when lever is rotated in up direction	Pawls (17) not engaging the brake disc (20). Due to spring failure, corrosion or contamination	Requires service for repair. Clean and inspect pawl and spring for proper function.
	Up, Dn Selector is not indexed correctly or spring (25) missing	Requires service for repair. Clean and inspect parts and assure proper assembly
	Bottom hook (80) and slack end pull handle (16) are assembled on the wrong end of the chain.	Requires service for repair. Looking at the lever end, the bottom hook (80) should be on the left side and the Pull handle (16) on the right.,

Continued on next page

10.0 TROUBLE SHOOTING (Continued)

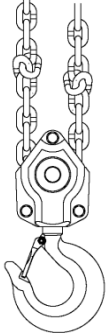
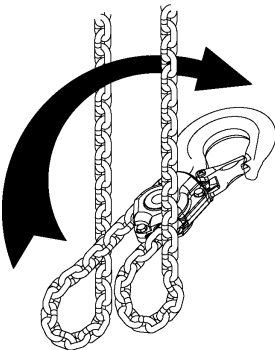
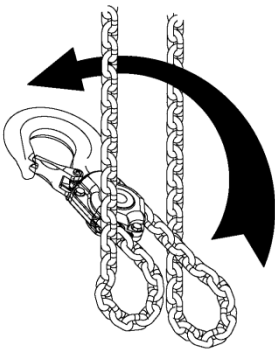
Trouble	Cause	Cure
Hoist will not lift. Slight clicking when lever is rotated in up direction	Brake disc (20) installed upside down not allowing the pawls (17) to engage.	Requires service for repair improper brake disc installation.
Hoist binds internally while lifting or lowering	Gearing improperly installed	Requires service for repair. Remove gear cover and inspect for proper gear timing per instruction and illustration in section 9.0 ASSEMBLY in this manual.
	Twisted or kinked chain was allowed to be ingested into the hoist.	Requires service for repair by disassembly to inspect for damage
Will not descend.	Brake is over tightened from shock load or removing the load by other than lowering with the hoist.	With the hoist selector in DN position, exert a hard sharp pull on the lever in the down direction.
 <p data-bbox="100 1029 274 1077">Twisted Chain on multiple part hoist</p>	 <p data-bbox="347 1045 644 1077">Capsized or flipped lower hook</p>	 <p data-bbox="761 1045 980 1077">Flip Lower hook block</p>

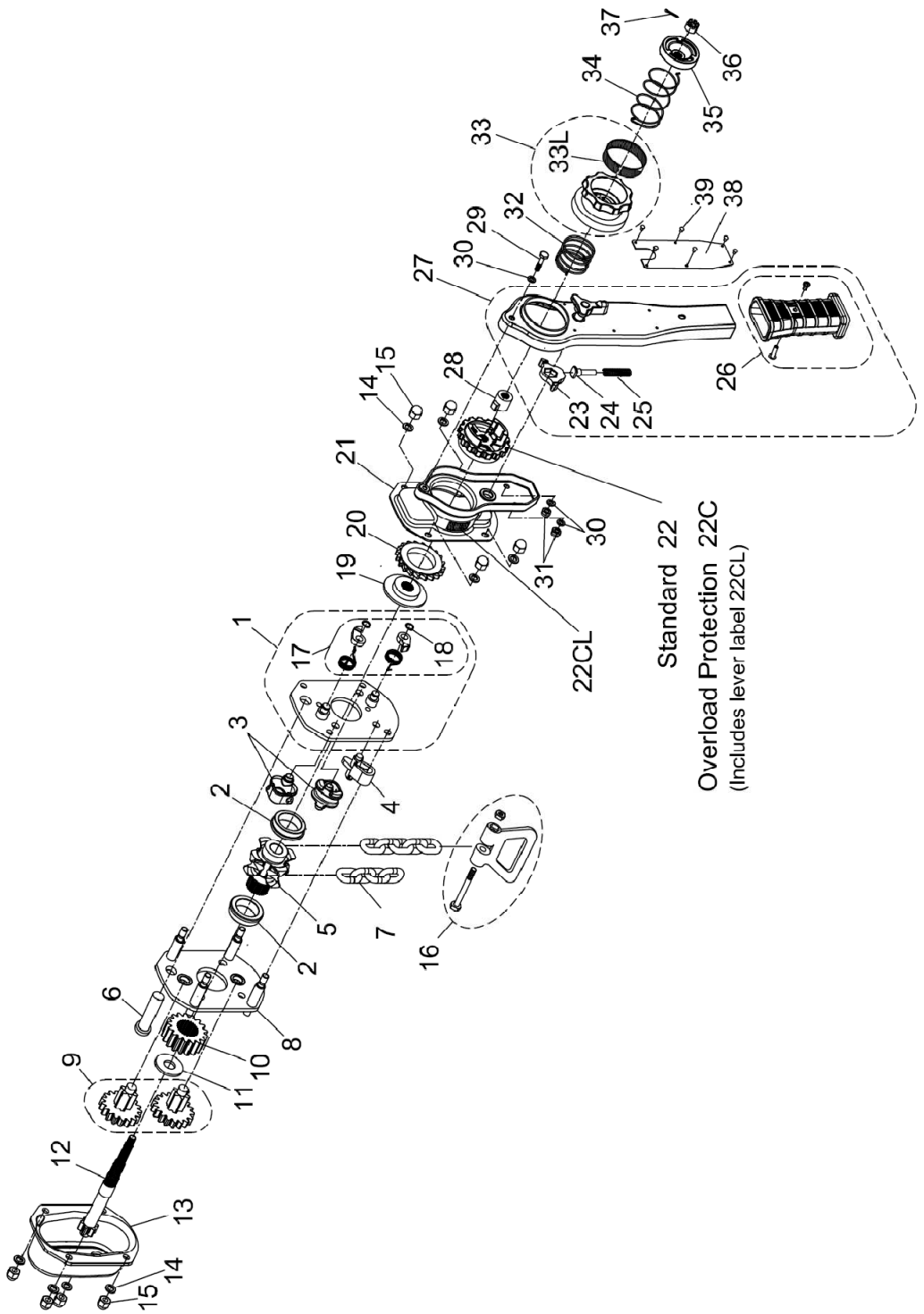

Standard 22
 Overload Protection 22C
 (Includes lever label 22CL)

#	X5L02250 (1 Part)	X5L03528 (1 Part)	X5L07056 (1 Part)	X5L14000 (2 Part)	X5L20000 (3 Part)
1	P-L02250-1	P-L03528-1		P-L07056-1	
*2	P-L02250-2	P-L03528-2		P-L07056-2	
3	P-L02250-3	P-L03528-3		P-L07056-3	
4	P-L02250-4	P-L03528-4		P-L07056-4	
5	P-L02250-5	P-L03528-5		P-L07056-5	
6	P-L02250-6	P-L03528-6		P-L07056-6	
7	C5.7H17Z	C7.1H20Z		C10H28Z	
8	P-L02250-8	P-L03528-8		P-L07056-8	
9	P-L02250-9	P-L03528-9		P-L07056-9	
10	P-L02250-10	P-L03528-10		P-L07056-10	
11	P-L02250-11	P-L03528-11		P-L07056-11	
12	P-L02250-12	P-L03528-12		P-L07056-12	
13	P-L02250-13	P-L03528-13		P-L07056-13	
14	P-M8 WASHER LOCK				
15	P-M8 NUT ACORN				
16	P-L02250-16	P-L03528-16		P-L07056-16	
*17	P-L02250-17			P-L07056-17	
18	P-L02250-18			P-L07056-18	
19	P-L02250-19			P-L07056-19	
*20	P-L02250-20			P-L07056-20	
21	P-L02250-21	P-L03528-21		P-L07056-21	
22	P-L02250-22	P-L03528-22		P-L07056-22	
22C	P-L02250-22C	P-L03528-22C		P-L07056-22C	
22CL	P-L02250-22CL				
23	P-L02250-23			P-L07056-23	
24	P-L02250-24			P-L07056-24	
25	P-L02250-25			P-L07056-25	
26	P-L02250-26	P-L03528-26		P-L07056-26	
27	P-L02250-27	P-L03528-27		P-L07056-27	
28	P-L02250-28			P-L07056-28	
29	P-M6X12 HEXHD			P-M8X12 HEXHD	
30	P-M6 WASHER LOCK			P-M8 WASHER LOCK	
31	P-M6 NUT HEX			P-M8 NUT HEX	
32	P-L02250-32			P-L07056-32	
33	P-L02250-33			P-L07056-33	
33L	P-L02250-33L			P-L07056-33L	
34	P-L02250-34			P-L07056-34	
35	P-L02250-35			P-L07056-35	
*36	P-M8 NUT SLOTTED-9.5			P-M10 NUT SLOTTED-12	
*37	P-M1.5X16 COTTER			P-M2X20 COTTER	
38	P-NPL-X5L02250	P-NPL-X5L03528-	P- NPL-X5L07056	P- NPL-X5L14000	P- NPL-X5L20000
39	P-M2.5X6 SCREW DRIVE				

*Recommended Spare Part

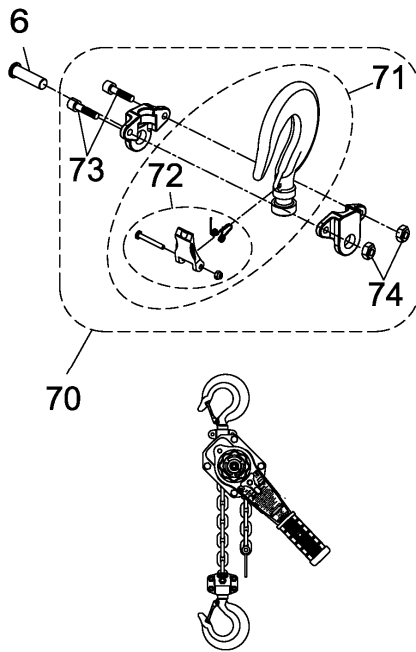

(1 Part)

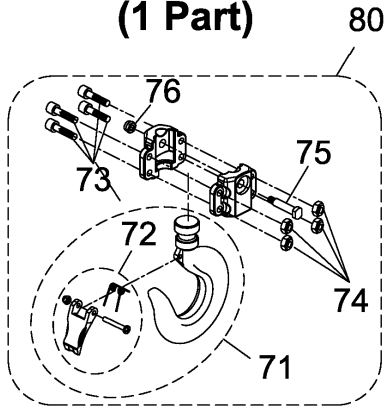

#	X5L02250 (1 Part)	X5L03528 (1 Part)	X5L07056 (1 Part)
70	P-L02250-70	P-L03528-70	P-L07056-70
*71	P-L02250-71	P-L03528-71	P-L07056-71
*72	P-L02250-72	P-L03528-72	P-L07056-72
73	P-M5X18 CSKHD	P-M6X22 CSKHD	
74	P-M5 NUT LOCK	P-M6 NUT LOCK	P-M6 NUT LOCK
75	P-L02250-75	P-L03528-75	P-L07056-75
76	P-M6 NUT LOCK	P-M8 NUT LOCK	P-M10 NUT LOCK
80	P-L02250-80	P-L03528-80	P-L07056-80
* Recommended Spare Part			

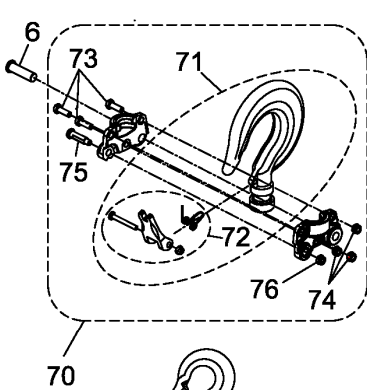

(2 Part)

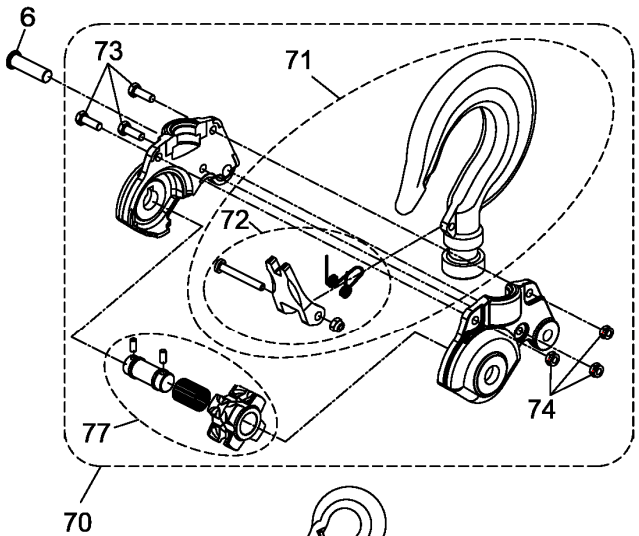

(3 Part)

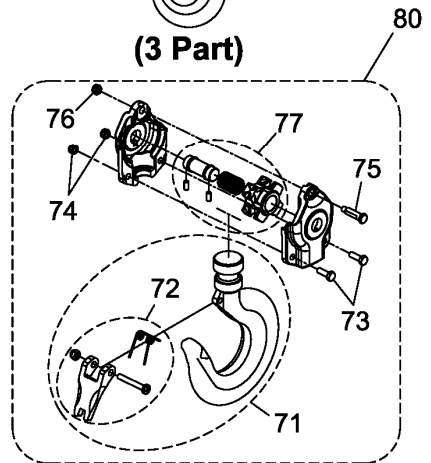
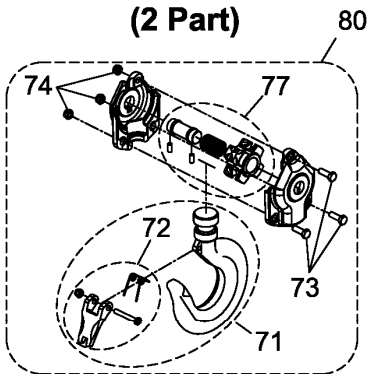

#	X5L14000 (2 Part)	X5L20000 (3 Part)
70	P-L14000-70	P-L20000-70
71	P-L14000-71	P-L20000-71
*72	P-L14000-72	P-L20000-72
73	P-M10X30 HEXHD	P-M10X35 HEXHD
74	P-M10 NUT LOCK	P-M10 NUT LOCK
75	P-L07056-75	P-L07056-75
76	P-M10 NUT LOCK	P-M10 NUT LOCK
77	P-L14000-77	P-L14000-77
80	P-L14000-80	P-L20000-80

*Recommended Spare Part

Model:	Serial No.:	Date:
--------	-------------	-------

PREOPERATION INSPECTION

**For New hoist and after inactivity of more than one month
in compliance with ASME B30 & OSHA**

New Hoist are to be inspected before use and **must be recorded**. No load test is required if tested and certified when manufactured. The new hoist test certification supplied with the hoist should be filed with the initial Preoperation Inspection. The date of this Preoperation Inspection, **not the date on the load test**, will become the start date for entering a new unit into service and determining timing of future periodic inspections.

Units returned to service after inactivity of more than one month, are to be inspected before use and **must be recorded**. This inspection does not affect the date of the next periodic test as previously scheduled.

Owners Name:		
Description :		
Working Load Limit (WLL):		
Evaluated by:		
Comments:		

Check List.

- a) Proper operation and any unusual sounds.
- b) Visually inspects hooks for deformation or bending and to verify latches function.
- c) Visually inspect Load chain for twist, damage or excessive wear between links.
- d) Visually inspect the Hoist body and lever for damage.
- e) Fasteners are in place and tight.
- f) Tail chain stop is in place.
- g) Nameplate and Warnings and operation instruction label are legible.

Model:	Serial No.:	Date:
---------------	--------------------	--------------

PERIODIC INSPECTION
in compliance with ASME B30 & OSHA

Required annually as a minimum and must be recorded. Periodic Inspection may be required more often as determined by severity of service or as experience dictates. Consult ASME B30.21 for determination of service and instruction. Periodic inspection is also required for repaired units. This inspection requires disassembly and load test prior to being returned to service.

Owners Name:			
Description :			
Working Load Limit (WLL):		Test Load:	
Evaluated by:			
Comments:			

Check List

- a) Proper operation and any unusual sounds.
- b) Visually inspects hooks for deformation or bending and to verify latches function.
- c) Visually inspect Load chain for twist, damage or excessive wear between links.
- d) Visually inspect the Hoist body and lever for damage.
- e) Fasteners are in place and tight.
- f) Tail chain stop is in place.
- g) Nameplate and Warnings and operation instruction label are legible.
- h) Visual inspection to determine that the unit is not compromised by corrosion or debris and can operate as intended.
- i) Make a trial lift or pull of a few inches and then stop to determine the hoist operates as intended.
- j) Continual observation during use for any damage or change in operation.
- k) Disassemble lever end of hoist to expose the brake components. Inspect brake pawls, disc, springs and ratchet surfaces for contamination or abnormal wear.
- l) Inspect; chain, springs and load bearing parts per INSPECTON MEASUREMENTS as illustrated in the Operation and Maintenance Manual.
- m) Disassemble hook blocks and check hooks 100% for any sign of cracks, bending, twist or stretching and opening measurement per INSPECTON MEASUREMENTS as illustrated in the Operation and Maintenance Manual.
- n) Check chain wheel or wheels for smooth operation and visually for wear.
- o) Check chain guide and guards for damage.
- p) Load test to minimum 125% of WLL (not more than 150% WLL). During which confirm function is as intended. After the test load is released inspect again for requirements of a) through j).

LIFETIME LIMITED WARRANTY

on Models: X5L02250, X5L03528, X5L07056, X5L14000 and X5L20000

We make every effort to assure that our products meet high quality and durability standards and we warrant to the original consumer of the product that each is free from defects in material and workmanship as follows:

This warranty does not apply to defects due directly or indirectly to misuse, negligence or accidents, repairs or alterations outside our facilities or to a lack of maintenance. The warranty begins with the date of purchased from an authorized AMH dealer by the original user. **Please retain your dated sales receipt as proof of purchase to validate the warranty.** Except as stated herein, any implied warranties or merchantability and fitness are excluded. AMH shall in no event be liable for death, injuries to persons or property or for incidental, contingent, special or consequential damages arising from the use of our products. Some states do not allow the exclusions or limitation of incidental or consequential damages; hence the above limitations or exclusions may not apply to you. To take advantage of this warranty, the product must be returned for examination, postage prepaid to an authorized service station. Proof of purchase date and an explanation of the complaint must accompany the product. **No returns will be accepted without prior authorization obtained through an AMH dealer.** If our inspection discloses a manufacturing defect we will either repair or replace the product or refund the purchase price, if we cannot quickly provide a repair or replacement, if you are willing to accept such a refund. We will return repaired products or the replacement at our expense, but if we find that there is no defect, or that the defect resulted from causes not within the scope of this warranty, then the user must bear the cost of returning the product. This warranty gives you specific legal rights, and you may also have other rights that vary from state to state.

Typical issues caused by misuse that are not covered by warranty:

- Bent, stretched or broken hooks
- Missing or sprung hook latch
- Bent or damaged lever
- Missing parts
- Corrosion
- Worn, deformed or stretched load chain
- Damage to chain guides and other parts from not allowing the hoist to form a straight line between hooks. Example is binding the hoist function by contact of the body with a structure.
- Wear from normal use.

AMH products are only sold through authorized dealers. The specifications and dimensions listed on the AMH website or in printed materials are provided as general information and are not binding. AMH reserves the right to alter equipment, parts, fittings, or accessories without prior notice for any reason.

This manual and other product information is available from: www.allmaterialhandling.com